

REVISIONS				
LTR	DESCRIPTION	DATE	DWN	APVD

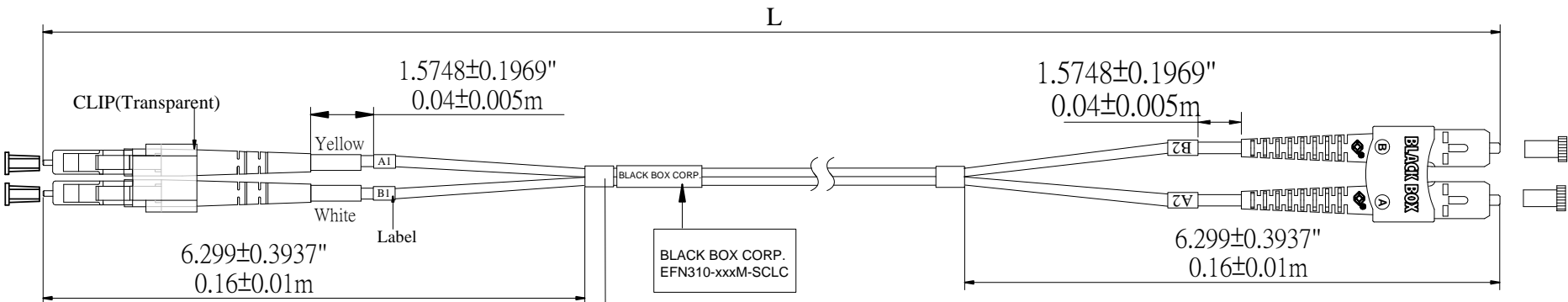

Test Label

P/N	EFN310-xxxM-SCLC		
S/N	Client Numbers(P/O)-Serial Number -N		
SC/LC;9/125;[Length]M			
DUPLEX FIBER OPTIC CABLE			
INSERTION LOSS	LOSS/RETURN	LOSS	
A1	/ dB	B1	/ dB
A2	/ dB	B2	/ dB

SC CONNECTOR SET

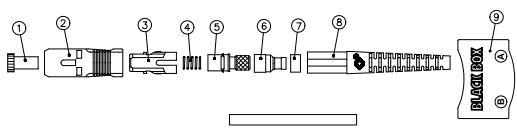

LC CONNECTOR SET

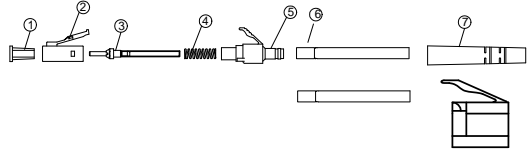

NO.	PART NAME
1	DUST CAP
2	HOLDER(BLUE)
3	FRAME
4	SPRING
5	STOPPING
6	CRIMP EYELET
7	CRIMP RING
8	BOOT(Black,3.0mm)
9	CLIP(BLACK)

N0	PART NAME
1	DUST CAP
2	PLUG HOUSING(BLUE)
3	BARREL/FERRULE
4	SPRING
5	EXTENDER CAP (BLUE)
6	CRIMP SLEEVE
7	CABLE SUPPORT(WHITE)

Specification

1. Marking: BLACK BOX CORPORATION GUARANTEED FOR LIFE (724) 746-5500 - - - SINGLEMODE FIBER CABLE - - ZIPCORD SMF-9/125 OFNR-(UL) E223839 xx/xxxx xxxM
2. Fiber: Singlemode Optical Fiber
3. Fiber cord: 2.0*4.2mm PVC-OFNR, Color Yellow
4. Operating wavelength: 1310nm
5. Insertion Loss: ≤ 0.2dB
6. Return Loss: ≥ 55dB

DWN	Nkx	9Sep2008			
CHK	9Sep2008				
APVD	9Sep2008	NAME	2.0*4.2mm Yellow PVC SC-LC 9/125 Patchcord		
UNIT:		DRAWING NO.	EFN310-xxxM-SCLC		
mm					
BLACK BOX			SCALE	SHEET	OF
			NTS	1	1
					REV
					0